

Since 1898
CONSEW®

CONSOLIDATED SEWING MACHINE CORP.

└ INDUSTRIAL SEWING & CUTTING EQUIPMENT

MODEL 14TU854

PARTS BOOK

1

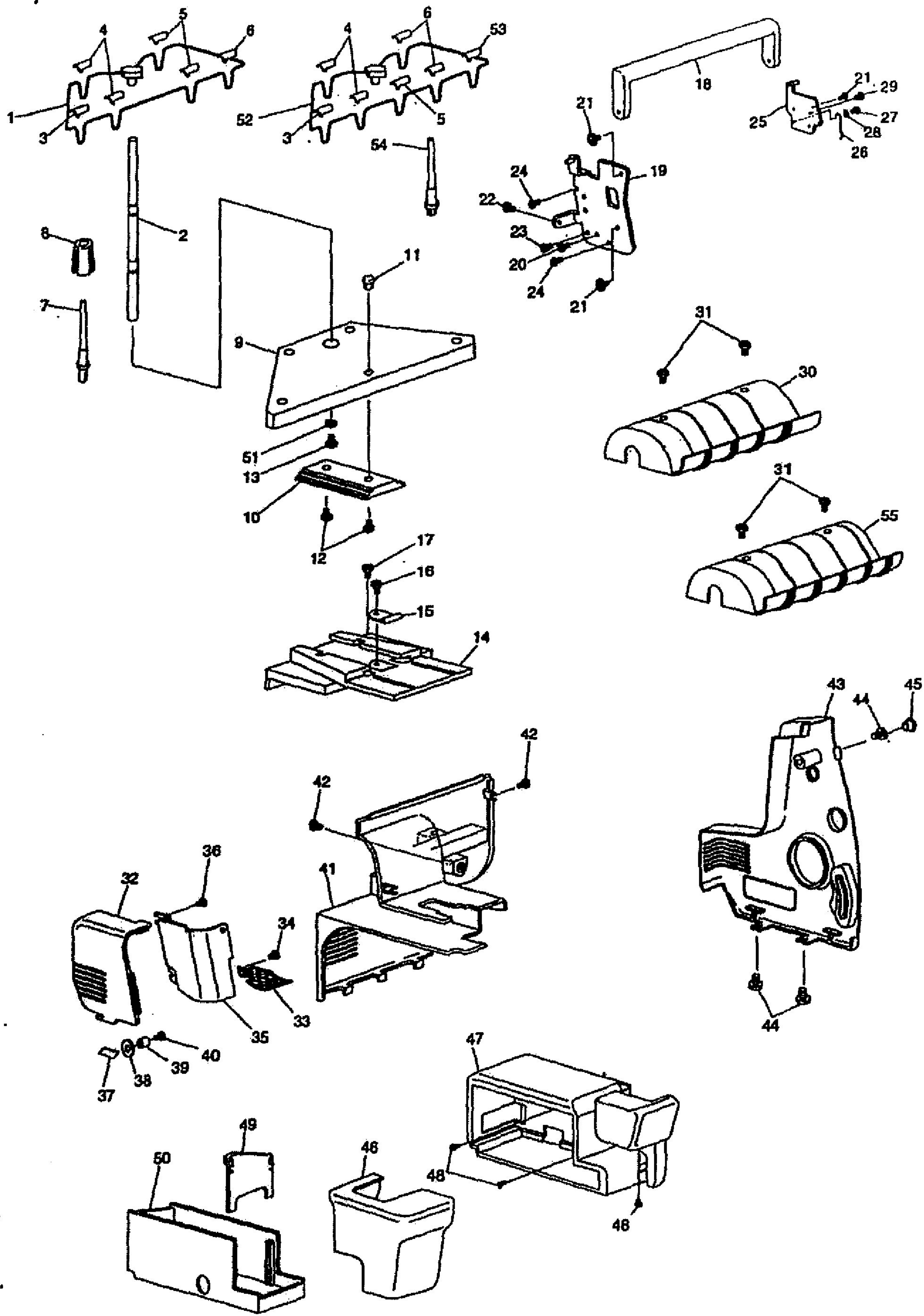

NO.	PART NO.	QTY.		DESCRIPTION
		854	857	
1	550705 *	1	-	THREAD UNWINDER THREAD GUIDE (UPPER) (FOR 4 THREAD)
2	550759	1	1	THREAD UNWINDER THREAD GUIDE ROD
3	550768-401	1	1	COLOR MARK (BLUE)
4	550768-402	2	2	COLOR MARK (GREEN)
5	550768-403	2	1	COLOR MARK (RED)
6	550768-404	1	2	COLOR MARK (YELLOW)
7	550702-391	4	4	SPOOL CENTER PIN
8	550703-391	4	5	SPOOL HOLDER
9	550698-391	1	1	THREAD UNWINDER PLATE
10	550699-391	1	1	THREAD UNWINDER SLIDE PLATE
11	550700-391	1	-	THREAD UNWINDER SLIDE PLATE NUT
12	544248-004	2	2	TAPPING SCREW (NOMINAL DIA.3, L12)
13	544212-003	1	1	SCREW (M4, L10)
14	550701-391	1	1	THREAD UNWINDER SUPPORT PLATE
15	550757	1	1	THREAD UNWINDER SUPPORT PLATE SPRING
16	544220-003	1	1	TAPPING SCREW (NOMINAL DIA.3, L8)
17	544270-001	1	1	SCREW (M4, L8)
18	550674-391	1	1	HANDLE
19	550679	1	1	HANDLE BRACKET (LEFT) COMP.
20	544211-002	1	1	SCREW (M3, L10)
21	544270-001	3	3	SCREW (M4, L8)
22	544270-001	1	1	SCREW (M4, L8)
23	544270-001	1	1	SCREW (M4, L8)
24	544212-001	2	2	SCREW (M4, L6)
25	550676	1	1	HANDLE BRACKET (RIGHT) COMP.
26	550391	1	1	PRESSER BAR LIFTER LEVER SPRING
27	544212-001	1	1	SCREW (M4, L6)
28	543803-003	1	1	WASHER
29	544212-001	1	1	SCREW (M4, L6)
30	550672-388	1	-	TOP COVER COMP. (FOR 4 THREAD)
31	544212-072	2	2	SCREW (M4, L8)
32	550688-391	1	1	LIGHT COVER
33	550689	1	1	LIGHT GRILLE
34	412697-002	1	1	TAPPING SCREW (NOMINAL DIA.4, L10)
35	550690	1	1	LIGHT SHIELD
36	412697-002	1	1	TAPPING SCREW (NOMINAL DIA.4, L10)
37	550334	1	1	THREAD CUTTER
38	543803-005	1	1	WASHER
39	543877-007	1	1	SPACER
40	543878-001	1	1	TAPPING SCREW (NOMINAL DIA.3, L6)
41	550476-391	1	1	REAR COVER COMP.
42	544270-001	2	2	SCREW (M4, L8)
43	550691-401	1	1	PULLEY COVER (GRAPHIC)
44	544270-001	3	3	SCREW (M4, L8)
45	550693-391	1	1	PULLEY COVER CAP
46	550694-391	1	1	CLOTH PLATE (FRONT) COMP.
47	550341-391	1	1	CLOTH PLATE (BACK)
48	544270-001	3	3	SCREW (M4, L8)
49	550342-391	1	1	ACCESSORY CASE PARTITION PLATE
50	550343-391	1	1	ACCESSORY CASE (LOWER)
51	543805-003	1	1	SPRING WASHER
52	556105	-	1	THREAD UNWINDER THREAD GUIDE (UPPER) (FOR 5 THREAD)
53	550768-405	-	1	COLOR MARK (PURPLE)
54	556091-391	-	1	SPOOL CENTER PIN (FOR 5 THREAD)
55	556092-388	-	1	TOP COVER COMP. (FOR 5 THREAD)

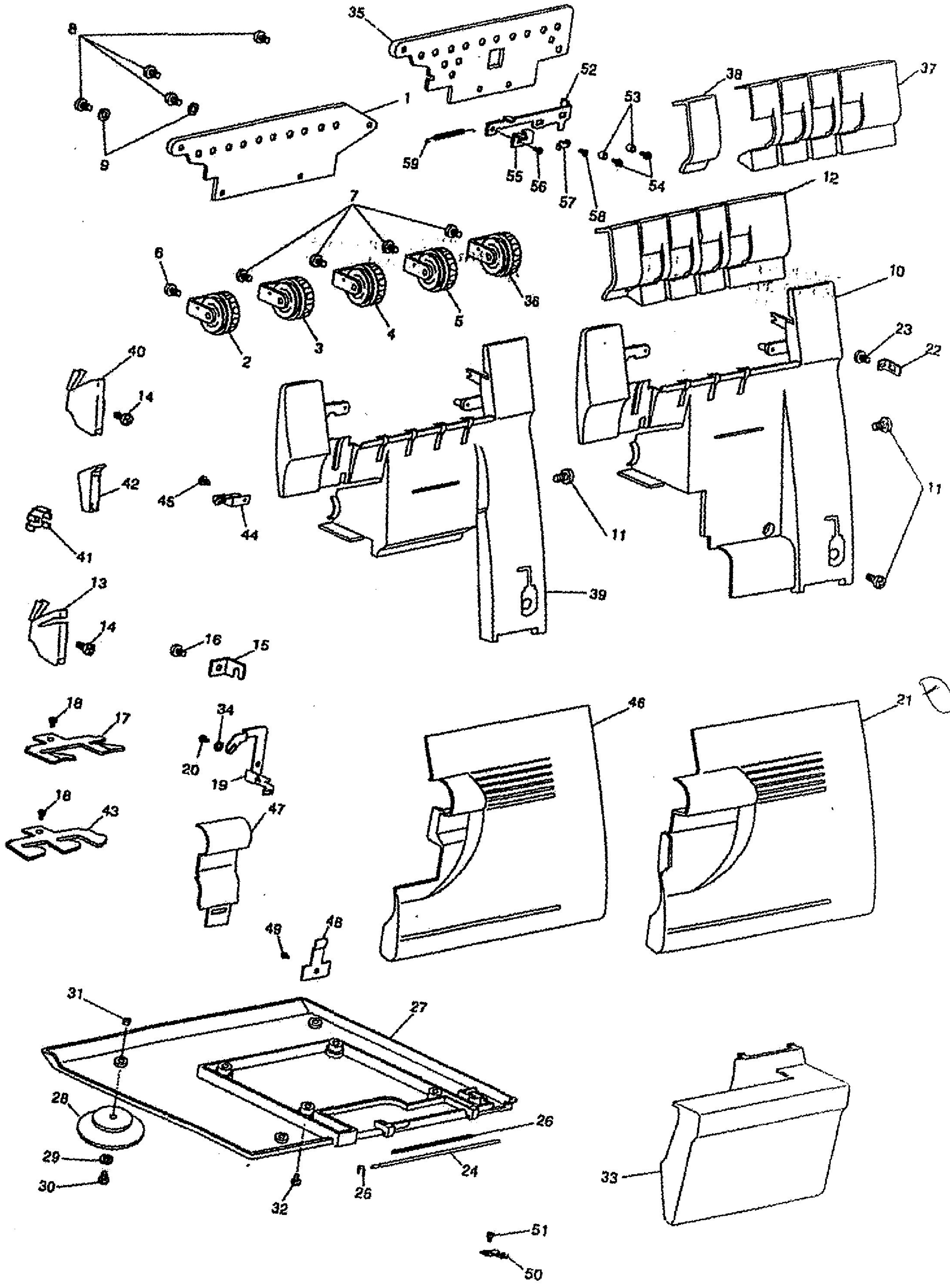

NO.	PART NO.	QTY.		DESCRIPTION
		854	857	
1	550714	1	-	TENSION DIAL BRACKET
2	550715-391	1	1	ONE TURN TENSION DIAL COMP. (LEFT NEEDLE THREAD)
3	550720-391	1	1	ONE TURN TENSION DIAL COMP. (RIGHT NEEDLE THREAD)
4	550721-391	1	1	ONE TURN TENSION DIAL COMP. (RIGHT LOOPER THREAD)
5	550722-391	1	1	ONE TURN TENSION DIAL COMP. (LEFT LOOPER THREAD)
6	544265	1	1	ONE TURN TENSION DIAL COMP. SCREW
7	544212-006	3	4	SCREW (M4, L5)
8	412697-002	4	4	TAPPING SCREW (NOMINAL DIA.4, L10)
9	543804-003	2	2	WASHER
10	550707-391	1	-	FRONT COVER (BODY) COMP. (FOR 4 THREAD)
11	544270-001	2	1	SCREW (M4, L8)
12	550711-388	1	-	TENSION DIAL COVER (GRAPHIC)
13	281487	1	-	FRONT COVER THREAD GUIDE (FOR 4 THREAD)
14	412697	1	1	TAPPING SCREW (NOMINAL DIA.4, L10)
15	412531	1	1	FRONT COVER THREAD GUIDE (SMALL)
16	412697-003	1	1	TAPPING SCREW (NOMINAL DIA.4, L8)
17	550352	1	-	FRONT COVER THREAD GUIDE (LOWER)
18	544211-002	1	1	SCREW (M3, L6)
19	550412	1	-	LOOPER THREAD GUIDE
20	412697-003	1	-	TAPPING SCREW (NOMINAL DIA.4, L8)
21	550682-401	1	-	LOOPER COVER (GRAPHIC)
22	550710	1	1	LOOPER COVER SUPPORT PLATE
23	544248-003	1	1	TAPPING SCREW (NOMINAL DIA.3, L6)
24	550327	1	1	LOOPER COVER HINGE PIN
25	543801-002	1	1	RETAINING RING
26	550328	1	1	LOOPER COVER HINGE PIN SPRING
27	550303-391	1	1	MACHINE BASE
28	410208	4	4	MACHINE BASE CUSHION
29	543803-004	4	4	WASHER
30	544218-003	4	4	SCREW (M5, L12)
31	541166-001	4	4	NUT (M5)
32	544213-005	4	4	SCREW (M6, L16)
33	550684-391	1	1	CLEAN POCKET COMP.
34	543804-003	1	-	WASHER
35	556117	-	1	TENSION DIAL BRACKET
36	556118-391	-	1	ONE TURN TENSION DIAL COMP. (CHAINSTITCH LOOPER THREAD)
37	556111-388	-	1	TENSION DIAL COVER (RIGHT) (GRAPHIC)
38	556113-388	-	1	TENSION DIAL COVER (LEFT) (GRAPHIC)
39	556107-391	-	1	FRONT COVER (BODY) COMP. (FOR 5 THREAD)
40	550775	-	1	FRONT COVER THREAD GUIDE (FOR 5 THREAD)
41	550776	-	1	NEEDLE THREAD GUIDE SUPPORT PLATE
42	550777-391	-	1	NEEDLE THREAD GUIDE
43	556110	-	1	FRONT COVER THREAD GUIDE (LOWER) (FOR 5 THREAD)
44	550779	-	1	THREAD CONTROLLER GUIDE SPRING COMP.
45	412697-003	-	1	TAPPING SCREW (NOMINAL DIA.4, L8)
46	556096-401	-	1	LOOPER COVER (BODY) COMP. (FOR 5 THREAD)
47	556100-391	-	1	CHIP GUARD
48	550426	-	1	CHIP GUARD PRESSER SPRING
49	412697-002	-	1	TAPPING SCREW (NOMINAL DIA.4, L10)
50	550772	-	1	CHAINSTITCH LOOPER GUIDE (SMALL)
51	544248-002	-	1	TAPPING SCREW (NOMINAL DIA.3, L8)
52	550786	-	1	TENSION RELEASE PLATE
53	543876-002	-	2	SPEGER
54	544270-003	-	2	SCREW (M4, L6)
55	550787	-	1	TENSION RELEASE AUXILIARY PLATE
56	544212-006	-	1	SCREW (M4, L5)
57	556055	-	1	TENSION RELEASE PLATE STOP PLATE
58	544212-001	-	1	SCREW (M4, L6)
59	550788	-	1	TENSION RELEASE PLATE SPRING

3

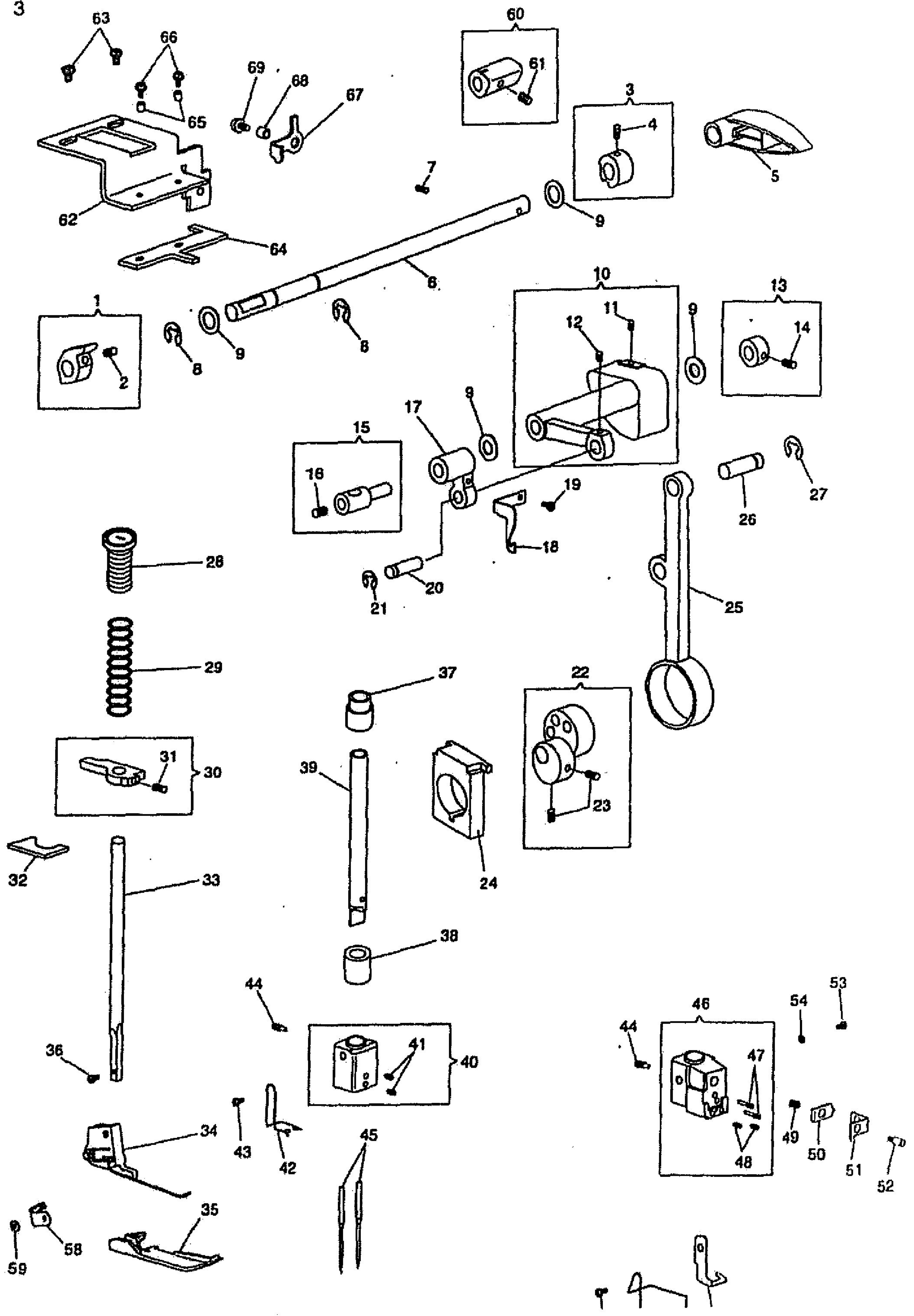

NO.	PART NO.	QTY.		DESCRIPTION
		854	857	
1	550386	1	1	PRESSER BAR LIFTER CAM (LEFT) COMP.
2	544207-011	1	1	SET SCREW (M4, L4)
3	550388	1	1	PRESSER BAR LIFTER CAM (RIGHT) COMP.
4	544207-011	1	1	SET SCREW (M4, L4)
5	550723-391	1	1	PRESSER BAR LIFTER LEVER
6	550392	1	1	ARM SHAFT
7	544207-012	1	1	SET SCREW (M4, L6)
8	543801-007	2	2	RETAINING RING
9	542402	4	4	THRUST WASHER
10	550404	1	1	NEEDLE BAR CRANK COMP.
11	544207-011	1	1	SET SCREW (M4, L4)
12	544207-011	1	1	SET SCREW (M4, L4)
13	550393	1	-	ARM SHAFT COLLAR COMP.
14	544207-011	1	-	SET SCREW (M4, L8)
15	410325	1	1	NEEDLE BAR CONNECTING STUD COMP.
16	544044	1	1	NEEDLE BAR CONNECTING STUD SCREW
17	410327	1	1	NEEDLE BAR CONNECTING LINK
18	281488	1	-	STRIKER (FOR 4 THREAD)
18	550401	-	1	STRIKER (FOR 5 THREAD)
19	544211-051	1	1	SCREW (M3, L5)
20	370270-900	1	1	NEEDLE BAR CONNECTING LINK PIN
21	543801-006	1	1	RETAINING RING
22	550402	1	1	NEEDLE BAR ECCENTRIC CAM COMP.
23	544207-011	2	2	SET SCREW (M4, L4)
24	550635	1	1	KNIFE (MOVABLE) FORKED LEVER SLIDE BLOCK
25	376804-900	1	1	NEEDLE BAR CRANK ROD
26	370270-900	1	1	NEEDLE BAR CONNECTING LINK PIN
27	543801-006	1	1	RETAINING RING
28	550370-391	1	1	PRESSER REGULATING THUMB COMP.
29	550372	1	1	PRESSER BAR SPRING
30	550373	1	1	PRESSER BAR GUIDE BRACKET COMP.
31	544207-011	1	1	SET SCREW (M4, L4)
32	650304	1	1	PRESSER BAR OIL FELT
33	410351	1	1	PRESSER BAR
34	550379-452	1	1	PRESSER FOOT SHANK COMP.
35	550376-452	1	1	PRESSER FOOT COMP.
36	504063-451	1	1	PRESSER FOOT SCREW
37	410323	1	1	NEEDLE BAR BUSHING (UPPER)
38	410324	1	1	NEEDLE BAR BUSHING (LOWER)
39	550395	1	1	NEEDLE BAR
40	550725	1	-	NEEDLE CLAMP (BODY) COMP. (FOR 4 THREAD)
41	374573	2	-	NEEDLE SET SCREW
42	376848	1	-	NEEDLE CLAMP THREAD GUIDE
43	544211-059	1	-	SCREW (M3, L4)
44	374102	1	1	NEEDLE CLAMP (BODY) SCREW
45	N2002-42-14	2	2	NEEDLE Cat. No. 2002 (14/90)
46	556120	-	1	NEEDLE CLAMP (BODY) COMP. (FOR 5 THREAD)
47	374365	-	2	NEEDLE SET SCREW (OVEREDGE NEEDLE)
48	374364	-	2	NEEDLE SET SCREW (COVER STITCH NEEDLE)
49	370233	-	1	NEEDLE THREAD PRE-TENSION SPRING
50	370231	-	1	NEEDLE THREAD PRE-TENSION PLATE
51	376637	-	1	NEEDLE THREAD PRE-TENSION BRACKET
52	374352	-	1	NEEDLE THREAD PRE-TENSION PLATE STUD SCREW
53	374353	-	1	NEEDLE THREAD PRE-TENSION BRACKET SCREW
54	546804-002	-	1	WASHER
55	550799	-	1	NEEDLE CLAMP THREAD GUIDE
56	550800	-	1	OVEREDGE NEEDLE THREAD GUIDE
57	374353	-	1	NEEDLE CLAMP THREAD GUIDE SET SCREW
58	550793	-	1	SEAM GUIDE HOLDER
59	543804-009	-	1	WASHER
60	550794	-	1	TENSION RELEASE CAM COMP.
61	544207-011	-	1	SET SCREW (M4, L4)
62	550790	-	1	TENSION RELEASE BRACKET
63	544212-001	-	2	SCREW (M4, L6)
64	550791	-	1	TENSION RELEASE ACTUATING PLATE
65	543876-002	-	2	SPECER

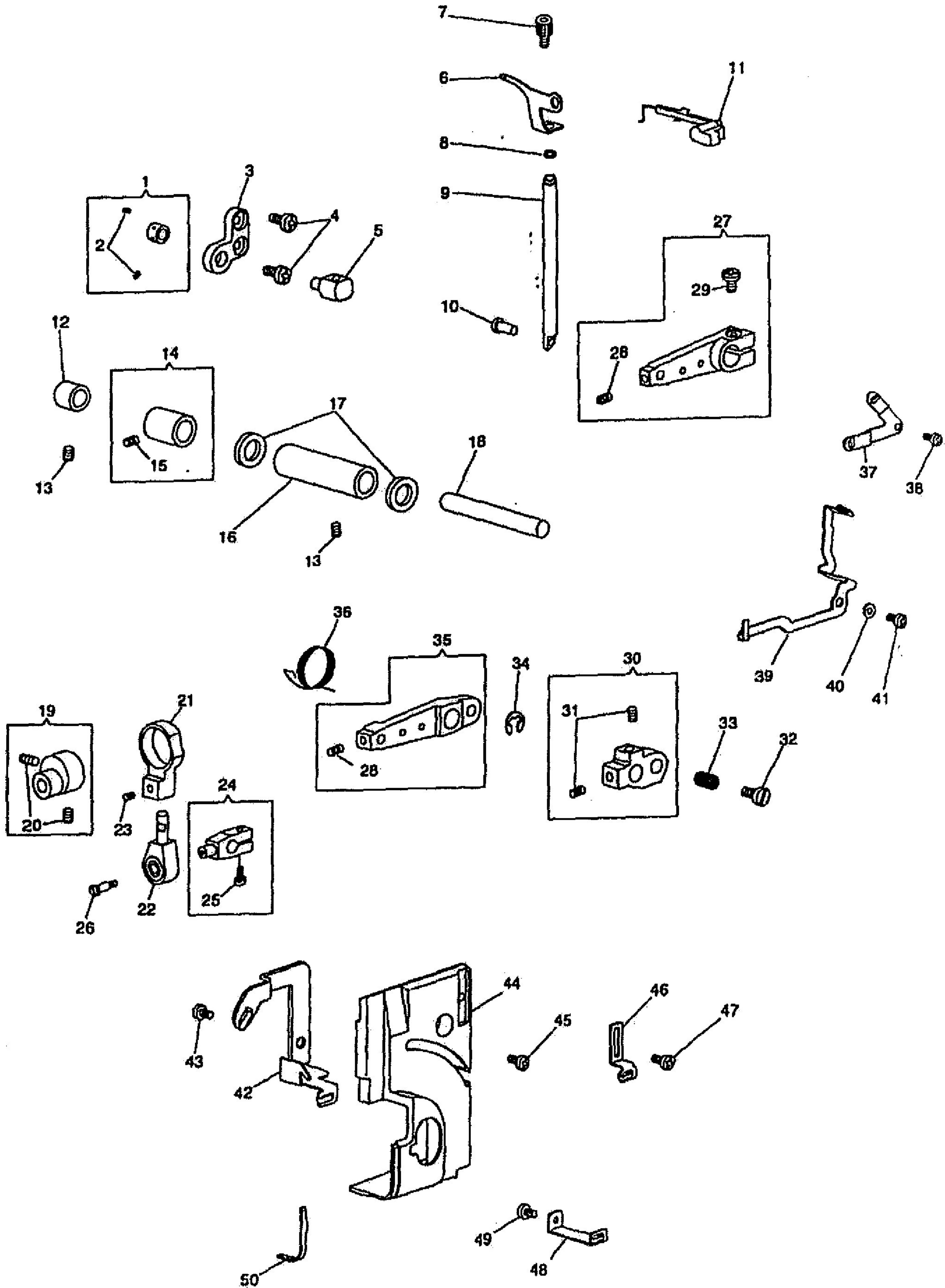

NO.	PART NO.	QTY.		DESCRIPTION
		854	857	
1	550396	1	1	RIGHT LOOPER RETAINER GUIDE COLLAR COMP
2	544207-011	2	2	SET SCREW (M4, L4)
3	370281	1	-	RIGHT LOOPER RETAINER GUIDE BRACKET
3	370272	-	1	RIGHT LOOPER REITANER GUIDE BRACKET
4	544213-002	2	2	SCREW (M6, L10)
5	410429	1	1	RIGHT LOOPER RETAINER GUIDE
6	550568	1	1	RIGHT LOOPER
7	414749-003	1	1	SCREW (M3, L6)
8	543871-006	-	1	O-RING
9	410435	1	1	RIGHT LOOPER RETAINER
10	370290	1	1	RIGHT LOOPER RETAINER DRIVING LEVER STUD
11	550547	1	1	SPREADER COMP.
12	550422	-	1	RIGHT LOOPER SHAFT BUSHING (BACK)
13	544207-011	1	2	SET SCREW (M4, L4)
14	550393	-	1	RIGHT LOOPER SHAFT COLLAR COMP.
15	544207-011	-	1	SET SCREW (M4, L4)
16	376799	1	-	RIGHT LOOPER SHAFT BUSHING
16	550421	-	1	RIGHT LOOPER SHAFT BUSHING (FRONT)
17	542402	2	2	THRUST WASHER
18	376813	1	-	RIGHT LOOPER SHAFT
18	556009	-	1	RIGHT LOOPER SHAFT
19	550477	1	1	RIGHT LOOPER CAM COMP.
20	544207-011	2	2	SET SCREW (M4, L4)
21	412794	1	1	RIGHT LOOPER CAM ROD
22	412795	1	1	RIGHT LOOPER CAM ROD END
23	544208-002	1	1	SET SCREW (M5, L8)
24	412796	1	1	RIGHT LOOPER SHAFT LEVER COMP.
25	414750-001	1	1	SCREW (M5, L12)
26	374136	1	1	RIGHT LOOPER CAM ROD END SCREW STUD
27	550587	1	-	RIGHT LOOPER RETAINER DRIVING LEVER COMP.
28	544207-011	1	1	SET SCREW (M4, L4)
29	544213-053	1	-	SCREW (M6, L12)
30	550586	-	1	RIGHT LOOPER RETAINER DRIVING LEVER (FRONT) COMP.
31	544208-005	-	2	SET SCREW (M5, L5)
32	550313	-	1	RIGHT LOOPER RETAINER DRIVING LEVER LOCK SCREW
33	550418	-	1	RIGHT LOOPER RETAINER DRIVING LEVER LOCK SCREW
				RETURN SPRING
34	543801-003	-	1	RETAINING RING
35	550597	-	1	RIGHT LOOPER RETAINER DRIVING LEVER (BACK) COMP.
36	550419	-	1	RIGHT LOOPER RETAINER DRIVING LEVER (BACK) RETURN
				SPRING
37	550406	1	1	RIGHT LOOPER THREAD GUIDE
38	544212-001	1	1	SCREW (M4, L6)
39	556010	-	1	CHAIN STITCH LOOPER THREAD GUIDE (LARGE)
40	543804-003	-	1	WASHER
41	544212-001	-	1	SCREW (M4, L6)
42	550412	-	1	LOOPER THREAD GUIDE
43	412697-003	-	1	TAPPING SCREW (NOMINAL DIA.4, L8)
44	556003-401	-	1	LOOPER THREAD GUIDE COVER
45	544270-001	-	1	SCREW (M4, L8)
46	556006	-	1	CHAIN STITCH LOOPER THREAD GUIDE (UPPER)
47	544248-002	-	1	TAPPING SCREW (NOMINAL DIA.3, L8)
48	556007	-	1	CHAIN STITCH LOOPER THREAD GUIDE (LOWER)
49	412697-003	-	1	TAPPING SCREW (NOMINAL DIA.4, L8)
50	556005	-	1	GUIDE PLATE FOR CHAIN STITCH LOOPER THREAD

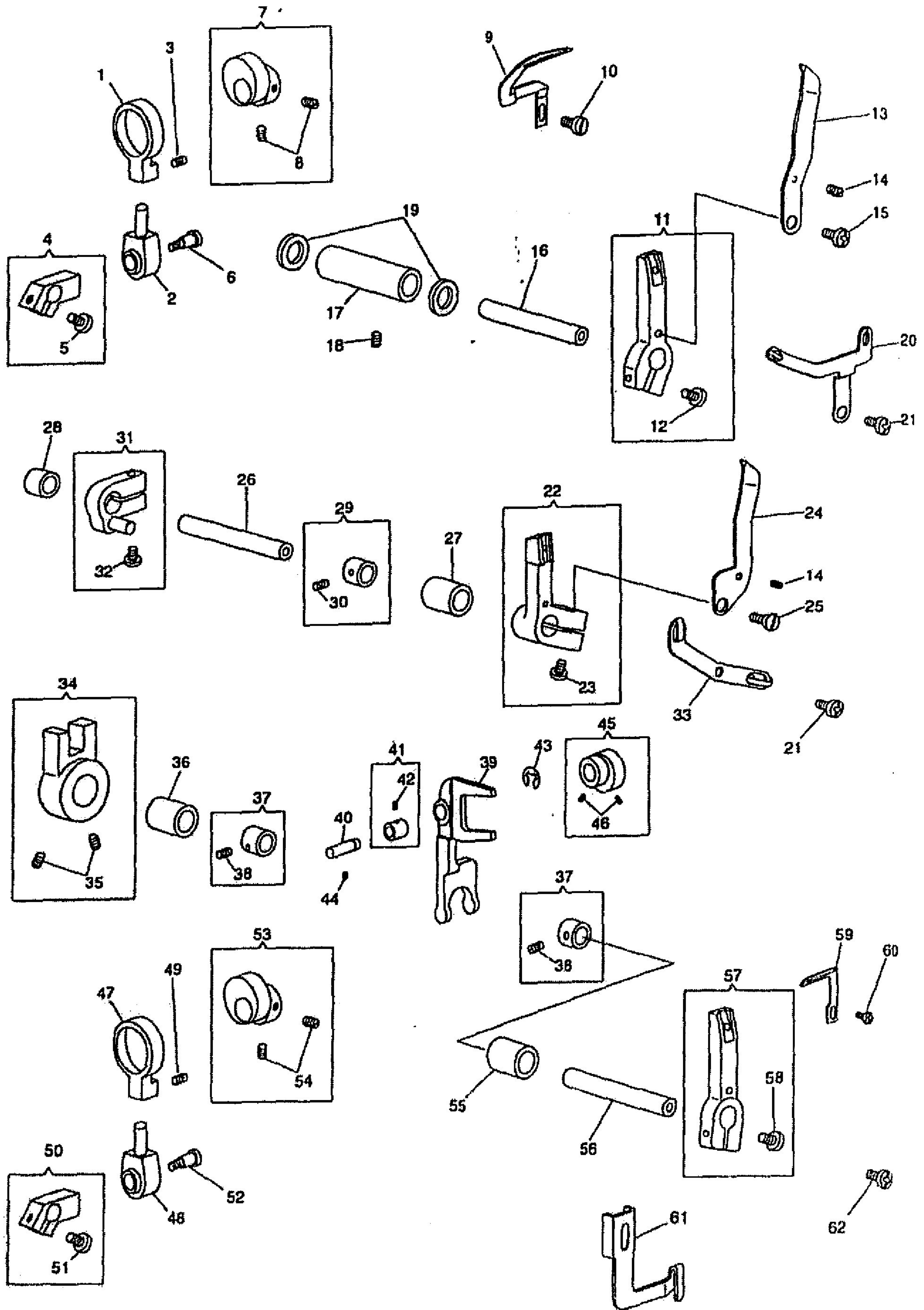

NO.	PART NO.	QTY.		DESCRIPTION
		854	857	
1	412794	1	-	LEFT LOOPER CAM ROD
2	412795	1	-	LEFT LOOPER CAM ROD END
3	544208-002	1	-	SET SCREW (M5, L8)
4	412798	1	-	LEFT LOOPER SHAFT LEVER COMP.
5	414750-001	1	-	SCREW (M5, L12)
6	374136	1	-	LEFT LOOPER CAM ROD END SCREW STUD
7	550477	1	-	LEFT LOOPER CAM COMP.
8	544207-011	2	-	SET SCREW (M4, L4)
9	550411	1	1	LEFT LOOPER
10	544211-052	1	1	SCREW (M3, L6)
11	550409	1	-	LEFT LOOPER HOLDER COMP.
12	414750-001	1	-	SCREW (M5, L12)
13	281481	1	-	NEEDLE GUARD (BACK) (FOR OVEREDGE NEEDLE)
14	374392	1	1	NEEDLE GUARD (BACK) (FOR OVEREDGE NEEDLE) ADJUSTING SCREW
15	544212-001	1	-	SCREW (M4, L6)
16	550407	1	-	LEFT LOOPER SHAFT
17	376798	1	-	LEFT LOOPER SHAFT BUSHING
18	544207-011	1	-	SET SCREW (M4, L4)
19	542402	2	-	THRUST WASHER
20	550410	1	-	LEFT LOOPER HOLDER THREAD GUIDE (FOR 4 THREAD)
21	544212-001	1	1	SCREW (M4, L6)
22	550428	-	1	LEFT LOOPER HOLDER COMP.
23	414750-001	-	1	SCREW (M5, L12)
24	376564	-	1	NEEDLE GUARD (BACK) (FOR OVEREDGE NEEDLE)
25	544258	-	1	NEEDLE GUARD (BACK) (FOR OVEREDGE NEEDLE) SCREW
26	376900	-	1	LEFT LOOPER SHAFT
27	410279	-	1	LEFT LOOPER SHAFT BUSHING (FRONT)
28	410280	-	1	LEFT LOOPER SHAFT BUSHING (BACK)
29	550393	-	1	LEFT LOOPER SHAFT COLLAR COMP.
30	544207-011	-	1	SET SCREW (M4, L4)
31	370203	-	1	LEFT LOOPER DRIVING ARM COMP.
32	544212-054	-	1	SCREW (M4, L12)
33	550429	-	1	LEFT LOOPER HOLDER THREAD GUIDE (FOR 5 THREAD)
34	370201	-	1	LEFT LOOPER DRIVING FORKED LEVER COMP.
35	544207-011	-	2	SET SCREW (M4, L4)
36	550422	-	1	CHAIN STITCH LOOPER SHAFT BUSHING (BACK)
37	550393	-	2	CHAIN STITCH LOOPER SHAFT COLLAR COMP.
38	544207-011	-	2	SET SCREW (M4, L4)
39	412565	-	1	CHAIN STITCH LOOPER AVOID CAM FORKED LEVER
40	412566-900	-	1	CHAIN STITCH LOOPER AVOID CAM FORKED LEVER STUD
41	410409	-	1	CHAIN STITCH LOOPER AVOID CAM FORKED LEVER STUD COLLAR COMP.
42	504007	-	1	CHAIN STITCH LOOPER AVOID CAM FORKED LEVER STUD COLLAR SCREW
43	543801-006	-	1	RETAINING RING
44	544207-011	-	1	SET SCREW (M4, L4)
45	550532	-	1	CHAIN STITCH LOOPER AVOID CAM COMP.
46	544206-011	-	2	SET SCREW (M3, L3)
47	412794	-	1	CHAIN STITCH LOOPER CAM ROD
48	412795	-	1	CHAIN STITCH LOOPER CAM ROD END
49	544208-002	-	1	SET SCREW (M5, L8)
50	376895	-	1	CHAIN STITCH LOOPER SHAFT LEVER COMP.
51	414750-001	-	1	SCREW (M5, L12)
52	374136	-	1	CHAIN STITCH LOOPER CAM ROD END SCREW STUD
53	556014	-	1	CHAIN STITCH LOOPER CAM COMP.
54	544207-011	-	2	SET SCREW (M4, L4)
55	550421	-	1	CHAIN STITCH LOOPER SHAFT BUSHING (FRONT)
56	550425	-	1	CHAIN STITCH LOOPER SHAFT
57	412551	-	1	CHAIN STITCH LOOPER HOLDER COMP.
58	414750-001	-	1	SCREW (M5, L12)
59	556080	-	1	CHAIN STITCH LOOPER
60	549364	-	1	CHAIN STITCH LOOPER SCREW
61	556012	-	1	CHAIN STITCH LOOPER HOLDER THREAD GUIDE
62	544212-001	-	1	SCREW (M4, L6)

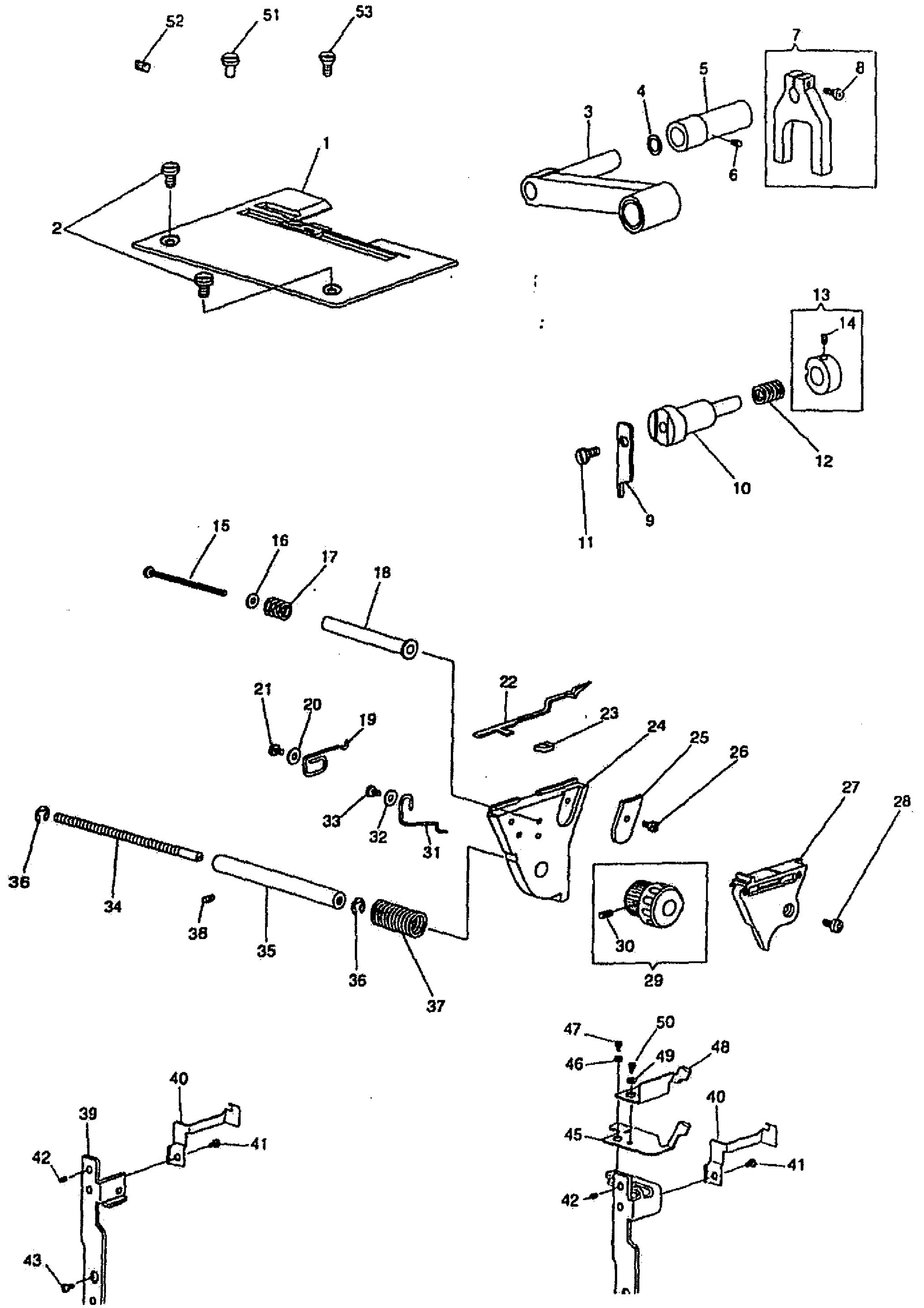

NO.	PART NO.	QTY.		DESCRIPTION
		854	857	
1	550443-452	1	-	THROAT PLATE (FOR 4 THREAD)
1	556016-452	-	1	THROAT PLATE (FOR 5 THREAD)
2	550553	2	-	THROAT PLATE POSITION SCREW
3	550437-391	1	1	KNIFE (MOVABLE) LEVER COMP.
4	542402	1	1	THRUST WASHER
5	550440	1	1	KNIFE (MOVABLE) FORKED LEVER STUD BUSHING
6	544207-011	1	1	SET SCREW (M4, L4)
7	550633	1	1	KNIFE (MOVABLE) FORKED LEVER COMP.
8	414750-004	1	1	SCREW (M5, L16)
9	412585	1	1	KNIFE (MOVABLE)
10	412586	1	1	KNIFE (MOVABLE) HOLDER
11	544407	1	1	KNIFE (MOVABLE) SCREW
12	410307	1	1	KNIFE (MOVABLE) HOLDER SPRING
13	550581	1	1	KNIFE (MOVABLE) HOLDER COLLAR COMP.
14	544207-011	1	1	SET SCREW (M4, L4)
15	414744-003	1	1	SCREW (M3, L58)
16	541217	1	1	KNIFE (STATIONARY) HOLDER STUD SCREW WASHER
17	412774	1	1	KNIFE (STATIONARY) HOLDER STUD SPRING
18	550457	1	1	KNIFE (STATIONARY) HOLDER STUD
19	550452	1	1	SEAM WIDTH FINGER SPRING
20	543803-002	1	1	WASHER
21	544211-002	1	1	SCREW (M3, L6)
22	550450	1	-	SEAM WIDTH FINGER
22	556043	-	1	SEAM WIDTH FINGER
23	550453-391	1	1	SEAM WIDTH FINGER KNOB
24	550448	1	1	KNIFE (STATIONARY) HOLDER
25	550449	1	1	KNIFE (STATIONARY)
26	544211-051	1	1	SCREW (M3, L5)
27	550451-391	1	1	SEAM WIDTH FINGER SUPPORT PLATE
28	544211-002	1	1	SCREW (M3, L6)
29	550748	1	1	SEAM WIDTH CONTROL DIAL COMP.
30	544207-011	1	1	SET SCREW (M4, L4)
31	550602	1	1	SEAM WIDTH CONTROL DIAL SPRING
32	543803-002	1	1	WASHER
33	544211-002	1	1	SCREW (M3, L6)
34	550549	1	1	SEAM WIDTH CONTROL SCREW
35	550456	1	1	SEAM WIDTH CONTROL SCREW BUSHING
36	543801-003	2	2	RETAINING RING
37	550359	1	1	SEAM WIDTH CONTROL SCREW SPRING
38	544207-011	1	1	SET SCREW (M4, L4)
39	550431	1	-	NEEDLE GUARD BRACKET
40	550432	1	1	NEEDLE GUARD (FRONT) (FOR OVEREDGE NEEDLE)
41	544211-001	1	1	SCREW (M3, L5)
42	374392-002	1	1	SET SCREW (M2.5, L5)
43	544212-001	1	1	SCREW (M4, L6)
44	556049	-	1	NEEDLE GUARD BRACKET
45	556047	-	1	NEEDLE GUARD (FRONT) FOR COVER STITCH NEEDLE
46	543804-002	-	1	WASHER
47	544211-001	-	1	SCREW (M3, L5)
48	556048	-	1	NEEDLE GUARD (BACK) FOR COVER STITCH NEEDLE
49	543804-002	-	1	WASHER
50	544211-001	-	1	SCREW (M3, L5)
51	556018	-	1	THROAT PLATE POSITIONING PIN (ECC.)
52	544207-011	-	1	SET SCREW (M4, L4)
53	374113	-	1	THROAT PLATE SCREW

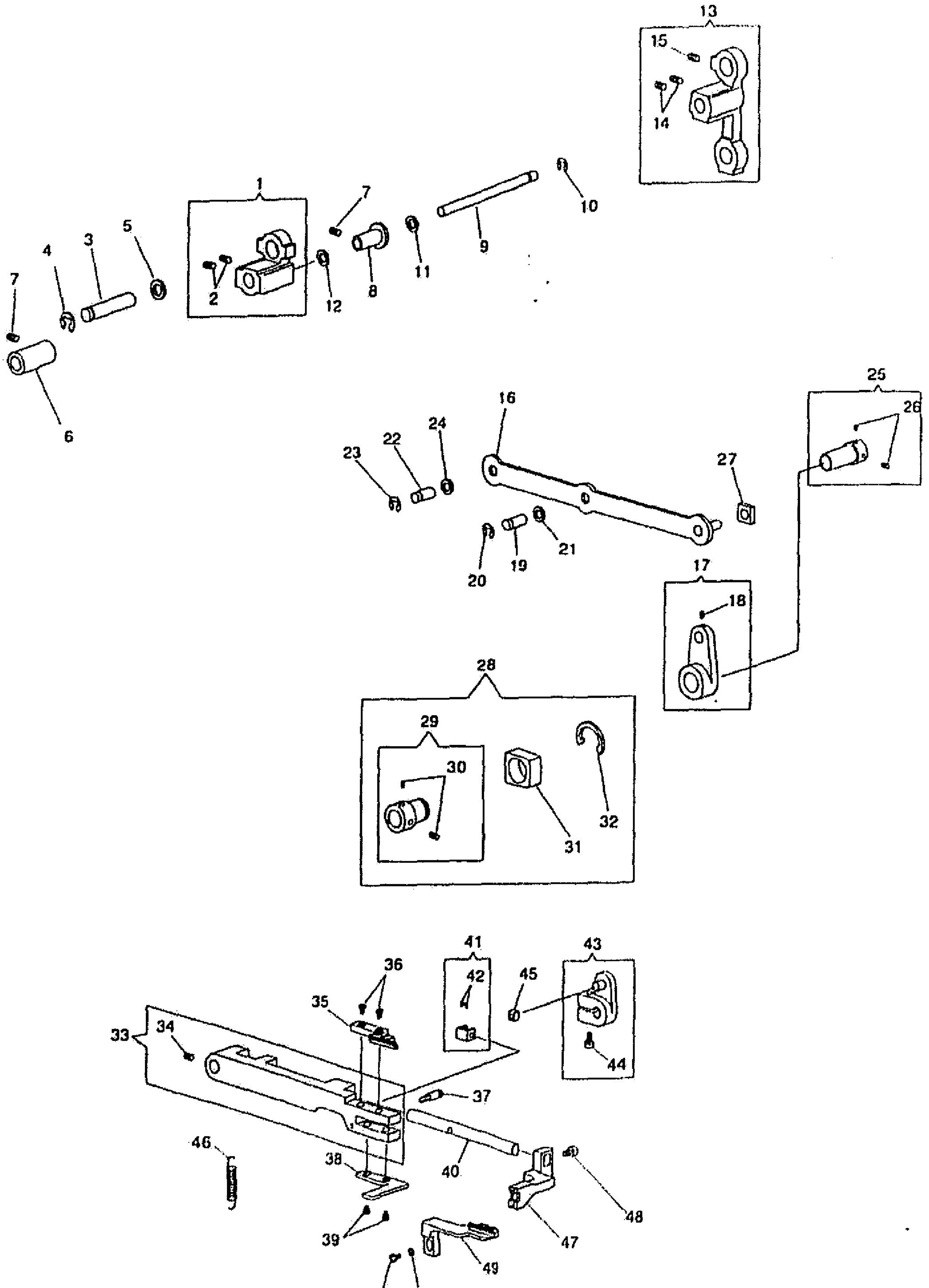

NO.	PART NO.	QTY.		DESCRIPTION
		854	857	
1	556019	1	1	FEED CRANK (LEFT) COMP.
2	544207-011	2	2	SET SCREW (M4, L4)
3	550473	1	1	FEED CRANK (LEFT) STUD
4	543801-006	1	1	RETAINING RING
5	542402	1	1	THRUST WASHER
6	550460	1	1	FEED CRANK SHAFT BUSHING (LEFT)
7	544207-011	2	2	SET SCREW (M4, L4)
8	550459	1	1	FEED CRANK SHAFT BUSHING (RIGHT)
9	550458	1	1	FEED CRANK SHAFT
10	543801-005	1	1	RETAINING RING
11	543531	1	1	THRUST WASHER
12	543815-006	1	1	THRUST WASHER
13	556082	1	1	FEED CRANK (RIGHT) (FOR DIFF. FEED) COMP.
14	544207-011	2	2	SET SCREW (M4, L4)
15	544207-011	1	1	SET SCREW (M4, L4)
16	556057	1	1	FEED REGULATOR CRANK ROD COMP.
17	550462	1	1	FEED CRANK ROD COMP.
18	544207-011	1	1	SET SCREW (M4, L4)
19	412635	1	1	FEED CRANK ROD STUD
20	543801-006	1	1	RETAINING RING
21	543531	1	1	THRUST WASHER
22	550469	1	1	FEED CRANK (RIGHT) STUD
23	543801-006	1	1	RETAINING RING
24	542402	1	1	THRUST WASHER
25	556086	1	1	FEED CAM COMP.
26	544207-011	2	2	SET SCREW (M4, L4)
27	556059	1	1	FEED REGULATOR SLIDE BLOCK
28	550578	1	-	FEED LIFTING CAM SLIDE BLOCK COMP. (FOR 4 THREAD)
28	550639	-	1	FEED LIFTING CAM SLIDE BLOCK COMP. (FOR 5 THREAD)
29	550579	1	-	FEED LIFTING CAM COMP. (FOR 4 THREAD)
29	550640	-	1	FEED LIFTING CAM COMP. (FOR 5 THREAD)
30	544207-011	2	2	SET SCREW (M4, L4)
31	410387	1	1	FEED LIFTING CAM SLIDE BLOCK
32	543818-010	1	1	RETAINING RING
33	556023	1	1	MAIN FEED BAR
34	544207-011	1	1	SET SCREW (M4, L4)
35	550499	1	-	MAIN FEED DOG (FOR 4 THREAD)
35	556025	-	1	MAIN FEED DOG (FOR 5 THREAD)
36	544211-002	2	2	SCREW (M3, L6)
37	550497	1	1	MAIN FEED BAR SPRING SCREW STUD
38	550498	1	1	AUXILIARY FEED SUPPORT BRACKET
39	544211-002	2	2	SCREW (M3, L6)
40	550500	1	1	AUXILIARY FEED BAR
41	556064	1	1	AUXILIARY FEED BAR SLIDE BLOCK GUIDE COMP.
42	544206-011	2	2	SET SCREW (M3, L3)
43	556067	1	1	DIFFERENTIAL FEED ARM COMP.
44	414751-001	1	1	SCREW (M4, L12)
45	556066	1	1	AUXILIARY FEED BAR SLIDE BLOCK
46	550509	1	1	MAIN FEED BAR SPRING
47	550501	1	1	AUXILIARY FEED DOG HOLDER
48	544211-002	1	1	SCREW (M3, L6)
49	550502	1	-	AUXILIARY FEED DOG (FOR 4 THREAD)
49	556027	-	1	AUXILIARY FEED DOG (FOR 5 THREAD)
50	544212-003	1	1	SCREW (M4, L10)
51	543804-003	1	1	WASHER

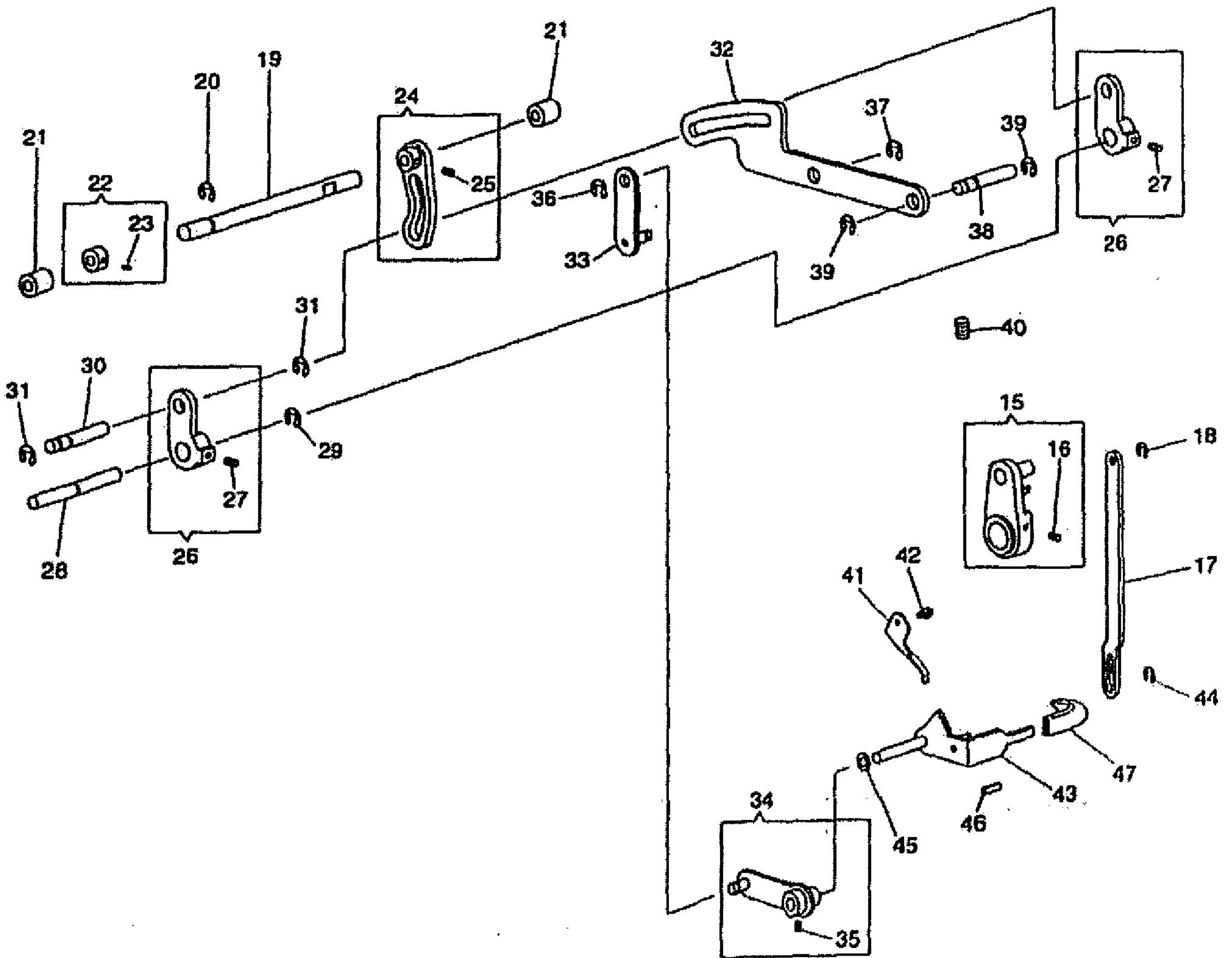
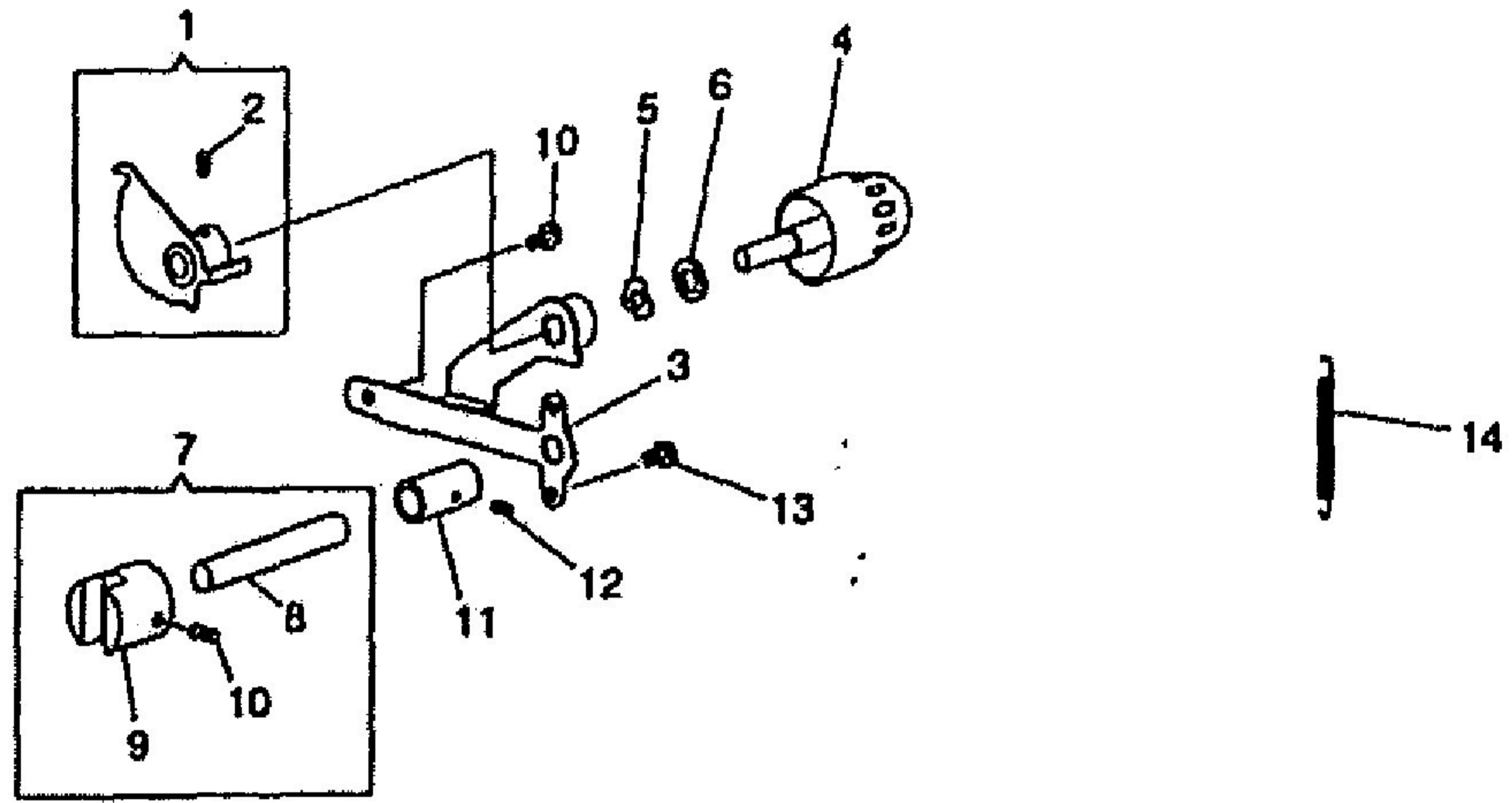

NO.	PART NO.	QTY.		DESCRIPTION
		854	857	
1	281406	1	1	FEED REGULATOR DRIVING CAM COMP.
2	544207-011	1	1	SET SCREW (M4, L4)
3	550485	1	1	FEED DIAL HUB COMP.
4	550728-401	1	1	FEED DIAL (GRAPHIC)
5	409213	1	1	FEED DIAL WAVE WASHER
6	543803-005	1	1	WASHER
7	556060	1	1	FEED REGULATOR COMP.
8	556062	1	1	FEED REGULATOR STUD
9	556061	1	1	FEED REGULATOR
10	544207-011	1	1	SET SCREW (M4, L4)
11	410370	1	1	FEED REGULATOR STUD BUSHING
12	544207-011	1	1	SET SCREW (M4, L4)
13	544212-001	2	2	SCREW (M4, L6)
14	281485	1	1	FEED REGULATOR LEVER SPRING
15	550490	1	1	FEED REGULATOR LEVER COMP.
16	544207-001	1	1	SET SCREW (M4, L4)
17	550523	1	1	DIFFERENTIAL FEED SAFETY PLATE
18	543801-002	1	1	RETAINING RING
19	550510	1	1	DIFFERENTIAL FEED SHAFT
20	543801-006	1	1	RETAINING RING
21	410324	2	2	DIFFERENTIAL FEED SHAFT BUSHING
22	375390	1	1	DIFFERENTIAL FEED SHAFT COLLAR COMP.
23	544207-011	1	1	SET SCREW (M4, L4)
24	556070	1	1	DIFFERENTIAL FEED ADJUSTING ARM COMP.
25	544207-011	1	1	SET SCREW (M4, L4)
26	556074	2	2	DIFFERENTIAL FEED ROD COMP.
27	544207-011	2	2	SET SCREW (M4, L4)
28	556077	1	1	DIFFERENTIAL FEED ROD (BACK)
29	543801-006	1	1	RETAINING RING
30	550756	1	1	DIFFERENTIAL FEED ROD (FRONT)
31	543801-006	2	2	RETAINING RING
32	550737	1	1	DIFFERENTIAL FEED ADJUSTING LEVER (LOWER)
33	550738	1	1	DIFFERENTIAL FEED LEVER LINK COMP.
34	550734	1	1	DIFFERENTIAL FEED LEVER COMP.
35	544207-011	1	1	SET SCREW (M4, L4)
36	543801-005	1	1	RETAINING RING
37	543801-006	1	1	RETAINING RING
38	550756	1	1	DIFFERENTIAL FEED ADJUSTING LEVER STUD
39	543801-006	2	2	RETAINING RING
40	544207-011	1	1	SET SCREW (M4, L4)
41	550524	1	1	DIFFERENTIAL FEED ADJUSTING LEVER SPRING
42	544270-001	1	1	SCREW (M4, L8)
43	550740	1	1	DIFFERENTIAL FEED ADJUSTING LEVER COMP.
44	543801-002	1	1	RETAINING RING
45	543803-005	1	1	WASHER
46	543808-003	1	1	DIFFERENTIAL FEED ADJUSTING LEVER PIN
47	550743-401	1	1	DIFFERENTIAL FEED ADJUSTING LEVER KNOB (GRAPHIC)

9 120V (FOR USA/CANADA)

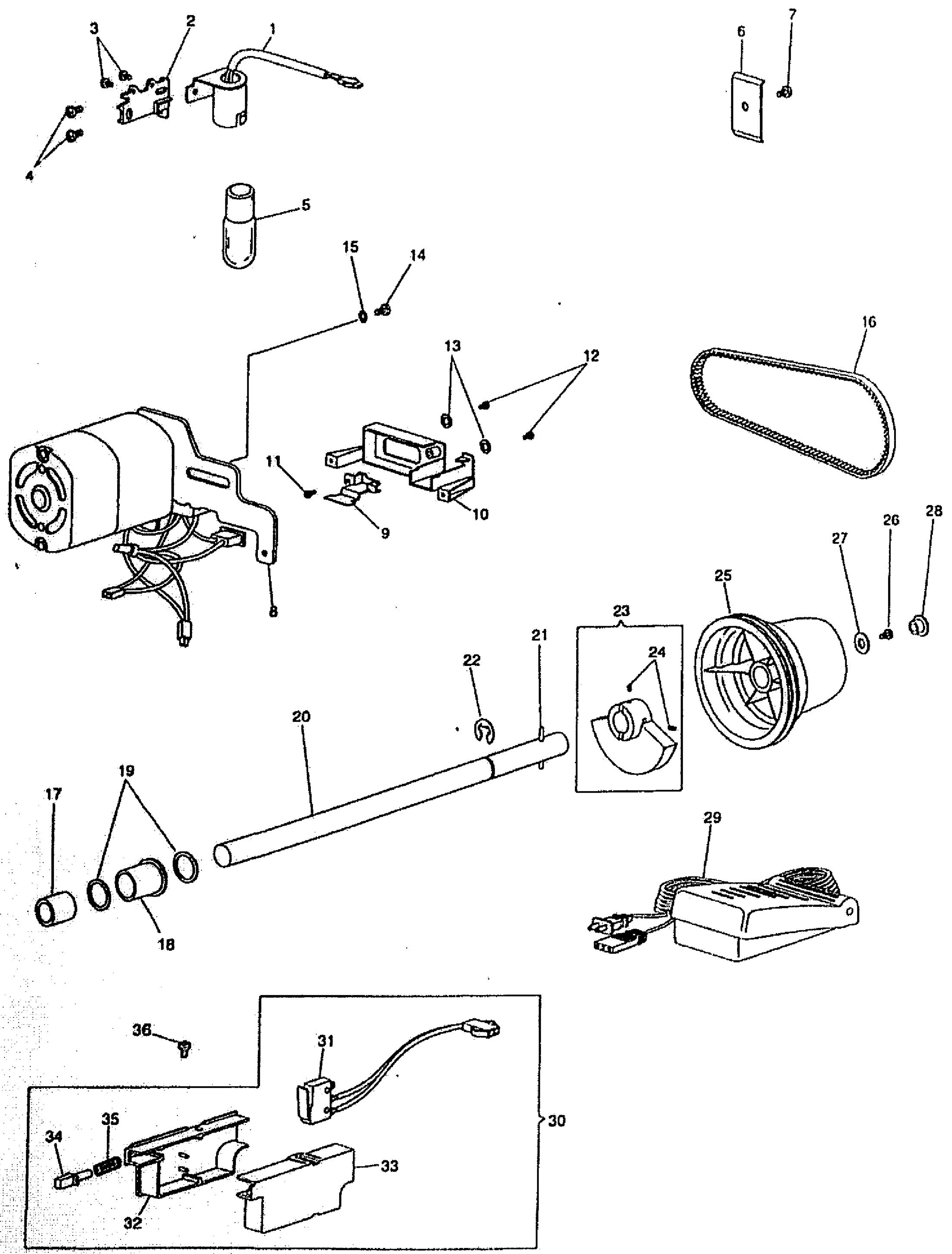

NO.	PART NO.	QTY.		DESCRIPTION
		854	857	
1	369308	1	1	LAMP HOLDER COMP. (FOR 120 - 127V)
2	281459	1	1	LAMP HOLDER BRACKET
3	544211-002	2	2	SCREW (M3, L6)
4	544212-002	2	2	SCREW (M4, L8)
5	194120-019	1	1	LAMP (FOR 120 - 127V, 15W, BAYONET TYPE)
6	550600	1	1	CORD CLAMPING PLATE
7	544212-001	1	1	SCREW (M4, L6)
8	369376	1	1	MOTOR COMP. (FOR 120V)
9	550530-391	1	1	SWITCH BOX (UPPER)
10	550554-391	1	1	SWITCH BOX (LOWER)
11	544248-002	1	1	TAPPING SCREW (NOMINAL DIA.3, L8)
12	544211-003	2	2	SCREW (M3, L8)
13	543805-002	2	2	WASHER
14	544499-001	1	1	SCREW (M6, L10)
15	543805-005	1	1	WASHER
16	412721	1	1	MOTOR BELT
17	410252	1	1	ROTATING SHAFT BUSHING (LEFT)
18	410253	1	1	ROTATING SHAFT BUSHING (RIGHT)
19	408730	2	2	ROTATING SHAFT THRUST WASHER
20	556090	1	1	ROTATING SHAFT
21	543808-004	1	1	SPRING PIN
22	543801-010	1	1	RETAINING RING
23	550754	1	1	ROTATING SHAFT BALANCE WEIGHT COMP.
24	544207-011	2	2	SET SCREW (M4, L4)
25	550745-391	1	1	PULLEY
26	544270-001	1	1	SCREW (M4, L8)
27	543848	1	1	WASHER
28	550746-391	1	1	PULLEY CAP
29	902-2301-033-011	1	1	CONTROLLER COMP. (110 - 127V) (TYPE AE033, PLUG A-TYPE)
30	369384-001	1	1	MICROSWITCH CASE COMP. (120V)
31	369397	1	1	MICROSWITCH CORD COMP. (120V)
32	550750-391	1	1	MICROSWITCH CASE (BODY)
33	550751-391	1	1	MICROSWITCH CASE (COVER)
34	550752	1	1	MICROSWITCH BUTTON
35	550753	1	1	MICROSWITCH BUTTON SPRING
36	544220-003	1	1	TAPPING SCREW (NOMINAL DIA.3, L8)

10 230V (FOR EUROPE)

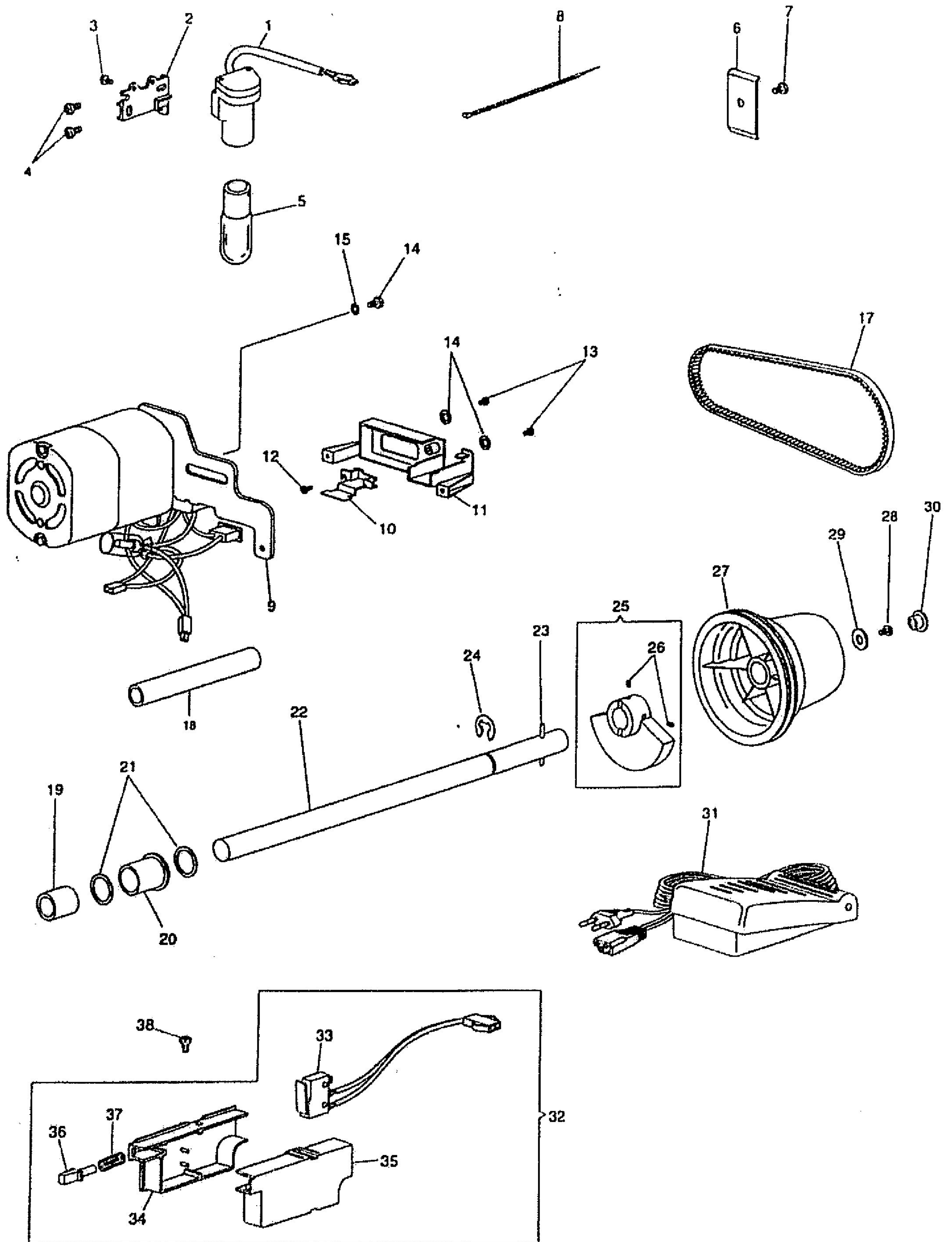

NO.	PART NO.	QTY.		DESCRIPTION
		854	857	
1	369370	1	1	LAMP HOLDER COMP. (FOR 200 - 240V)
2	281459	1	1	LAMP HOLDER BRACKET
3	544211-002	1	1	SCREW (M3, L6)
4	544212-002	2	2	SCREW (M4, L8)
5	194120-021	1	1	LAMP (FOR 220 - 240V, 15W, BAYONET TYPE)
6	550600	1	1	CORD CLAMPING PLATE
7	544212-001	1	1	SCREW (M4, L6)
8	540899	2	2	CORD RETAINER
9	369378	1	1	MOTOR COMP. (FOR 230V)
10	550530-391	1	1	SWITCH BOX (UPPER)
11	550555-391	1	1	SWITCH BOX (LOWER)
12	544248-002	1	1	TAPPING SCREW (NOMINAL DIA.3, L8)
13	544211-003	2	2	SCREW (M3, L8)
14	543805-002	2	2	WASHER
15	544499-001	1	1	SCREW (M6, L10)
16	543805-005	1	1	WASHER
17	412721	1	1	MOTOR BELT
18	419161-906	2	2	TUBE (FOR 220 - 240V)
19	410252	1	1	ROTATING SHAFT BUSHING (LEFT)
20	410253	1	1	ROTATING SHAFT BUSHING (RIGHT)
21	408730	2	2	ROTATING SHAFT THRUST WASHER
22	556090	1	1	ROTATING SHAFT
23	543808-004	1	1	SPRING PIN
24	543801-010	1	1	RETAINING RING
25	550754	1	1	ROTATING SHAFT BALANCE WEIGHT COMP.
26	544207-011	2	2	SET SCREW (M4, L4)
27	550745-391	1	1	PULLEY
28	544270-001	1	1	SCREW (M4, L8)
29	543848	1	1	WASHER
30	550746-391	1	1	WASHER CAP
31	902-2301-030-001	1	1	CONTROLLER COMP. (220 - 240V) (TYPE AE030, PLUG C-TYPE)
32	369384-002	1	1	MICROSWITCH CASE COMP. (200 - 240V)
33	369385	1	1	MICROSWITCH CORD COMP. (200 - 240V)
34	550750-391	1	1	MICROSWITCH CASE (BODY)
35	550751-391	1	1	MICROSWITCH CASE (COVER)
36	550752	1	1	MICROSWITCH BUTTON
37	550753	1	1	MICROSWITCH BUTTON SPRING
38	544220-003	1	1	TAPPING SCREW (NOMINAL DIA.3, L8)

11 240V(FOR AUSTRALIA)

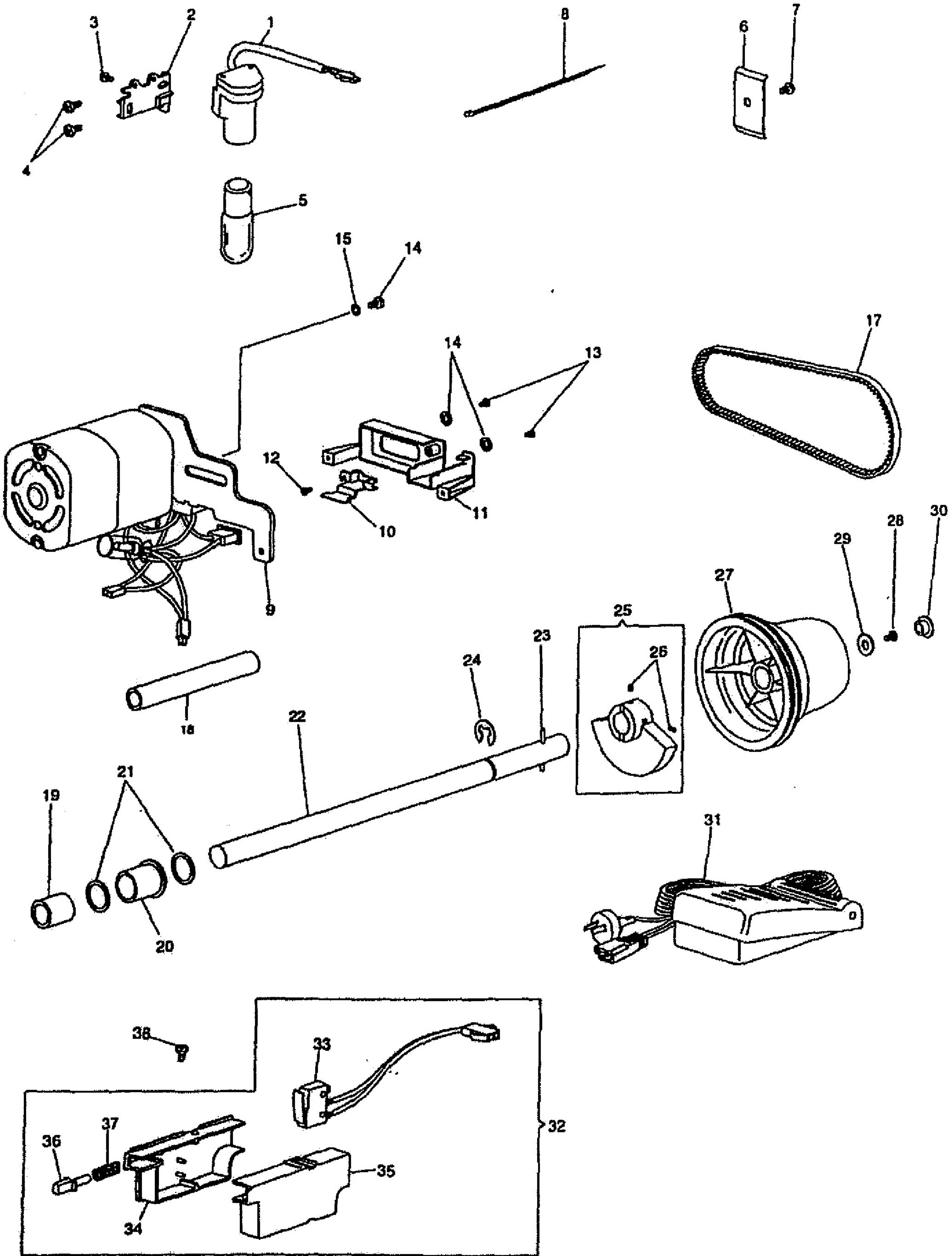

NO.	PART NO.	QTY.		DESCRIPTION
		854	857	
1	369370	1	1	LAMP HOLDER COMP. (FOR 200 - 240V)
2	281459	1	1	LAMP HOLDER BRACKET
3	544211-002	1	1	SCREW (M3, L6)
4	544212-002	2	2	SCREW (M4, L8)
5	194120-021	1	1	LAMP (FOR 220 - 240V, 15W, BAYONET TYPE)
6	550600	1	1	CORD CLAMPING PLATE
7	544212-001	1	1	SCREW (M4, L6)
8	540899	2	2	CORD RETAINER
9	369380	1	1	MOTOR COMP. (FOR 240V)
10	550530-391	1	1	SWITCH BOX (UPPER)
11	550555-391	1	1	SWITCH BOX (LOWER)
12	544248-002	1	1	TAPPING SCREW (NOMINAL DIA.3, L18)
13	544211-003	2	2	SCREW (M3, L8)
14	543805-002	2	2	WASHER
15	544499-001	1	1	SCREW (M6, L10)
16	543805-005	1	1	WASHER
17	412721	1	1	MOTOR BELT
18	419161-906	2	2	TUBE (FOR 220 - 240V)
19	410252	1	1	ROTATING SHAFT BUSHING (LEFT)
20	410253	1	1	ROTATING SHAFT BUSHING (RIGHT)
21	408730	2	2	ROTATING SHAFT THRUST WASHER
22	556090	1	1	ROTATING SHAFT
23	543808-004	1	1	SPRING PIN
24	543801-010	1	1	RETAINING RING
25	550754	1	1	ROTATING SHAFT BALANCE WEIGHT COMP.
26	544207-011	2	2	SET SCREW (M4, L4)
27	550745-391	1	1	PULLEY
28	544270-001	1	1	SCREW (M4, L8)
29	543848	1	1	WASHER
30	550746-391	1	1	WASHER CAP
31	902-2301-034-011	1	1	CONTROLLER COMP. (220 - 240V) (TYPE AE034, PLUG S-TYPE)
32	369384-002	1	1	MICROSWITCH CASE COMP. (200 - 240V)
33	369385	1	1	MICROSWITCH CORD COMP. (200 - 240V)
34	550750-391	1	1	MICROSWITCH CASE (BODY)
35	550751-391	1	1	MICROSWITCH CASE (COVER)
36	550752	1	1	MICROSWITCH BUTTON
37	550753	1	1	MICROSWITCH BUTTON SPRING
38	544220-003	1	1	TAPPING SCREW (NOMINAL DIA.3, L8)

NO.	PART NO.	QTY.		DESCRIPTION
		854	857	
1	546358	1	1	BRUSH
2	376638	1	1	TWEEZERS
3	541513-946	1	1	SCREW DRIVER (MEDIUM)
4	541514	1	1	SCREW DRIVER (SMALL)
5	552218	1	1	NEEDLE PACK (N2002-42 11/80X2, 14/90X3)
6	550449	1	1	KNIFE (STATIONARY)
7	546894	4	5	THREAD UNWINDER SPOOL CAP
8	550610	1	1	OILER
9	543131	4	5	THREAD UNWINDER SPOOL NET
10	29-629993-62	1	-	INSTRUCTION MANUAL
11	552219-401	1	1	MACHINE COVER (WITH PFAFF MARK)
12	556125-391	-	1	SEAM GUIDE PLATE
13	556126	-	1	WELT GUIDE
14	374105	-	1	WELT GUIDE SCREW
15	556033	-	1	SEAM GUIDE
16	556032-452	-	1	COVER STITCH THROAT PLATE
17	556030-452	-	1	COVER STITCH PRESSER FOOT
18	556127-391	-	1	NEEDLE INSERTER

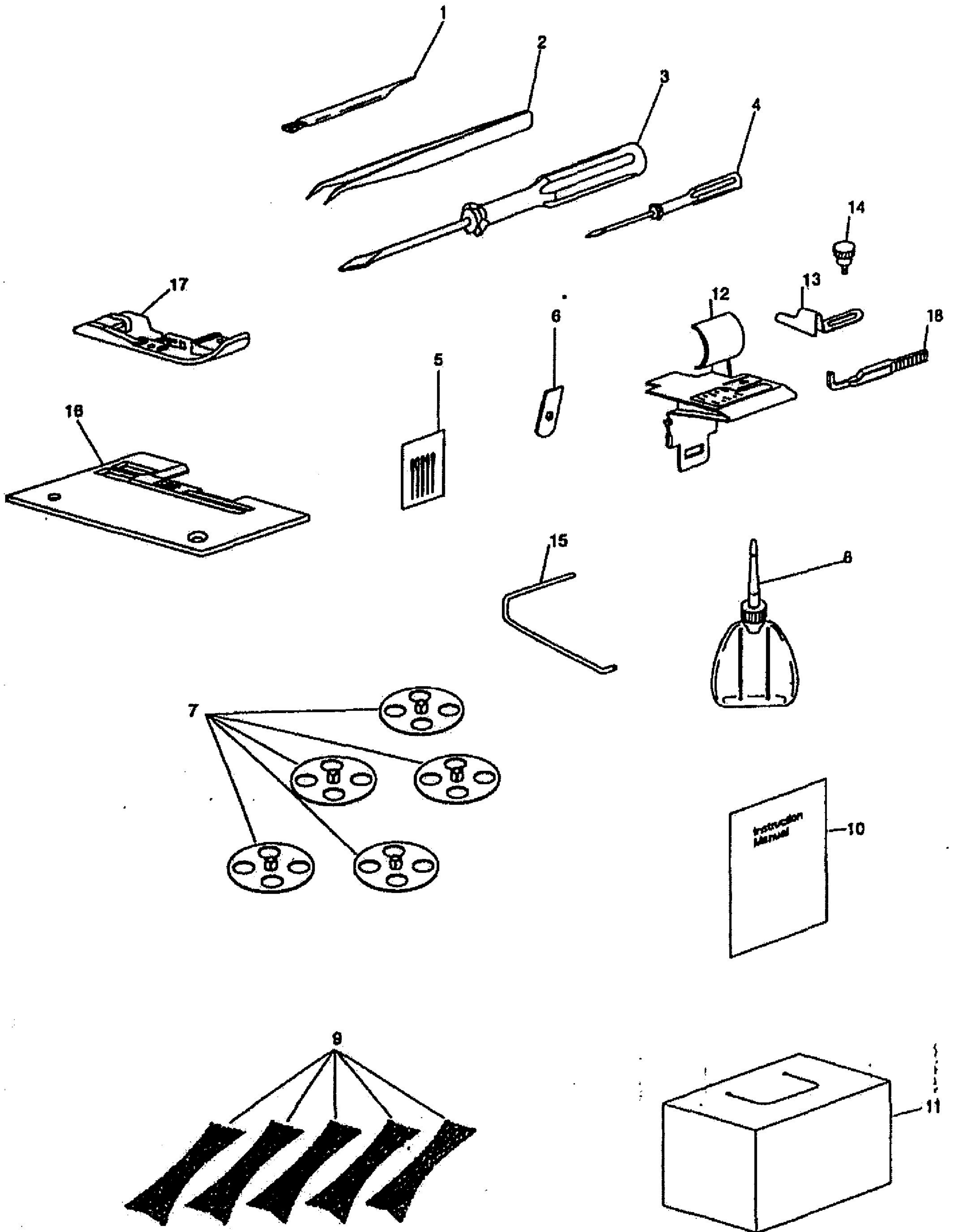

Consolidated Sewing Machine Corp.

website: www.consew.com

MAIN office

131 W. 25th Street
New York, NY 10001
Tel: 212-741-7788
Fax: 212-741-7787
e-mail: consew@att.net

Miami, FL

7855 N.W. 29th Street, Bay 166
Miami, FL 33122
Tel: 305-471-0200
Fax: 305-471-0243
e-mail: miamisales@consew.com

Los Angeles, CA

1400 South Boradway
Los Angeles, CA 90015
Tel: 213-745-8844
Fax: 213-745-8855
e-mail: lasales@consew.com